



**NAFA<sup>®</sup>**  
**National Air  
Filtration  
Association**

# Guidelines

Recommended Practices for  
Filtration for Higher Education Complexes



This NAFA Guideline has been provided, courtesy of:

**Independent Filter Service**  
82 Northern Road,  
Heidelberg West, 3081, Victoria  
T: (03) 9458 3644  
E: [sales@independentfilter.com.au](mailto:sales@independentfilter.com.au)  
[www.independentfilter.com.au](http://www.independentfilter.com.au)



**INDEPENDENT  
FILTER  
SERVICE P/L**

# About this publication

**NAFA®**

## Why NAFA Guidelines?

The National Air Filtration Association (NAFA) provides “Best Practice Guidelines” to help supplement existing information on the control and cleaning of air through proper filtration. Many organizations recommend “minimum” air cleaning levels. NAFA publishes best practice based on the experience and expertise of our membership along with information and research of the governmental, medical and scientific communities showing the short and long term impact particulate and molecular contaminants have on human health and productivity.

This Guideline provides advice on achieving the cleanest air possible based on the design limits of existing HVAC equipment and with consideration of the impact on energy and the environment. For a more complete explanation of principles and techniques found in this Guideline, go to the website [www.nafahq.org](http://www.nafahq.org) and purchase the *NAFA Guide to Air Filtration*, 4th Edition.

**Copyright © National Air Filtration Association 2004, 2015.**

All rights reserved.

## Copyright and Limitations on Use

The information available through NAFA® Guidelines is the property of The National Air Filtration Association® (NAFA) and is protected by copyright and other intellectual property laws. Information received through the NAFA Guidelines may be displayed, reformatted and printed for your personal, non-commercial use only. You agree not to reproduce, re-transmit, distribute, disseminate, sell, publish, broadcast or circulate the information to anyone, including but not limited to others in the same company or organization as you, without the expressed prior written consent of NAFA with the following exception:

You may, on occasion, include isolated portions of information from NAFA Guidelines in official memoranda, unit newsletters, reports, and presentations, but only if such memoranda, reports, and client presentations are distributed or otherwise made available in non-electronic form, for a non-commercial purpose to a limited number of individuals. You must include in all such memoranda, reports, and presentations the phrase, “Used with permission of The National Air Filtration Association®.” You may not post any content from the NAFA Guidelines to any newsgroup, mail list, electronic bulletin board or other forum without the prior written consent of NAFA.

## Disclaimer

The information contained in this Guideline is intended for reference purposes only. NAFA has used its best efforts to assure the accuracy of information and industry practice. NAFA encourages the user to work with a NAFA Certified Air Filter Specialist (CAFS), to assure that these Guidelines address specific user equipment and facility needs.

Issues regarding health information may be superseded by new developments in the field of industrial hygiene. Users are therefore advised to regard these recommendations as general guidelines and to determine whether new information is available.

NAFA does not guarantee, certify or assure the performance of any products (other than those bearing the NAFA Certified Product label), components, or systems operated in accordance with NAFA Guidelines.

**National Air Filtration Association**  
(NAFA)

22 N. Carroll St, Ste 300

Madison, WI 53703

(608) 310-7542

[nafahq.org](http://nafahq.org)

# Committee members and contributors

*Committee Chair :*  
**Trey Fly, CAFS, NCT II**  
Joe W. Fly Co., Inc.

**Benny Aycoth, CAFS**  
TEX-Air Filters

**Mike Beier, CAFS**  
Products Unlimited, Inc.

**Mike Block, CAFS, NCT**  
Green Air LLC

**Steven Brown, CAFS, NCT II**  
TEX-AIR Filters

**Bill Cawley, CAFS**  
Flanders Corporation

**Carol Christensen, CAFS**  
The Filter Man, Ltd.

**Larry Clark, CAFS**  
Clark Air Systems, Inc.

**Kevin Delahunt, CAFS**  
B.G.E. Service & Supply Ltd.

**Harry C. Elinsky, Jr., CAFS**  
Filtech, Inc.

**Layton Hindsman, CAFS, NCT II**  
Air Filter Sales & Service

**Rupert Langston, CAFS**  
Air Flow Technology, Inc.

**Paula Levasseur, CAFS**  
Cameron Great Lakes, Inc.

**Stephen W. Nicholas, CAFS, NCT II**  
Air Industries, Inc.

**Domenick Orlando, CAFS**  
Dave Downing & Associates

**Phil Maybee, CAFS**  
The Filter Man, Ltd.

**Bill Palmer**  
AeroMed, Inc.

**Bill Patterson, CAFS**  
Dave Downing & Associates

**Steve Peege, CAFS**  
Columbus Industries, Inc.

**Jay Reese, CAFS**  
3M Purification, Inc.

**Thomas Riddell, CAFS, NCT II**  
Air Filter Sales & Service

**Patrick Rosenthal, CAFS**  
TEX-Air Filters

**Wayne Vickers, CAFS**  
Columbus Industries, Inc.

**Rick Wells, CAFS**  
Northeast Air Solutions, Inc.

**Bob Williams, CAFS**  
Superior Fibers LLC

**Chris Zaker, CAFS, NCT**  
Glasfloss Industries, Inc.

# Table of Contents

Purpose.....	2
Scope.....	2
Background.....	2
Higher Education HVAC Systems	
System Approach Central Air Handling Units	
Rooftop air handling units.....	2
Make-up air units.....	2
Unitary units.....	2
Unit ventilators.....	2
Fan coil units.....	3
Self contained units	3
Heat pumps	
Induction units	
Application Approach.....	3
Localized supply exhaust.....	4
Internal construction	
Food preparation	
Business processing center	
Health safety	
Operation and Maintenance.....	5
Installation of filter and system integrity.....	5
Maintenance.....	5
Monitoring of airflow and pressure drop	
Disposal	
Summary.....	7
Glossary.....	8
Bibliography.....	9

# Filtration for Higher Education Complexes

## Purpose

This best practice air filtration guideline is established for the removal of particulate and molecular contaminants (please refer to NAFA Guidelines for Molecular Filtration) for the improvement of indoor air quality and protection of HVAC equipment in Higher Education facilities. It serves to provide the facility managers with the necessary tools to make measurable differences to the operation of the HVAC systems in their campus through air filtration.

## Scope

This best practice guideline will address the filtration practices associated with the complex systems and applications found in today's Higher Education buildings. It will take into consideration indoor environment and equipment protection. It will look at operating and maintenance of filtration systems as well as conditions such as renovations, internal construction and localized exhaust. This will include many different building types found on a Higher Education campus. Included in this list, but not limited to would be classrooms, science buildings, libraries, student living, offices, and sports complexes.

## Background

Higher Education facilities are always under constraints to achieve high quality education at affordable cost. With new research showing the benefits of cleaner environments on learning and health, our students and faculty should have cleaner air to breathe.<sup>1</sup> Increased training and knowledge can help keep indoor air quality (IAQ) affordable and achievable.

While cutting small costs for proper air filtration may show an immediate savings impact on the budget, keeping up with proper preventative maintenance and scheduled air filter changes will have a more sustainable impact in the long run. Without proper maintenance and filtration, key components of HVAC systems will deteriorate, resulting in costly repairs or increase operating costs.

## Higher Education HVAC Systems

The way air conditioning and maintenance is handled in Higher Education complexes is going to vary greatly depending on the institution, its size, age of buildings, and age of delivery equipment. Some Higher Education complexes will have commercial grade HVAC systems with single stage filtration. Many of these systems are dated and have been using filters with a very low minimum efficiency. It is essential to clean evaporator coils, fans, and all other major components of HVAC systems when implementing a new filtration system. Cleaning the system and installing higher efficiency/low pressure drop filters may achieve lower pressure in the system, reduced energy costs, higher airflow and higher levels of particle removal resulting in cleaner air.

Higher Education buildings of today provide more than just a space for professors and students to work and learn. They are small communities that can include restaurants, health clubs, medical clinics, science buildings, libraries, parking garages, living quarters, research labs and more. For a facility management team this presents some unique challenges. Specialized mechanical equipment is required for servicing these varied applications and the unique activities associated with them. The following mechanical equipment and applications can be found in some, or all, Higher Education buildings.

<sup>1</sup> See Pawel Wargocki, PhD, "Improving Indoor Air Quality Improves the Performance of Office Work and School Work"

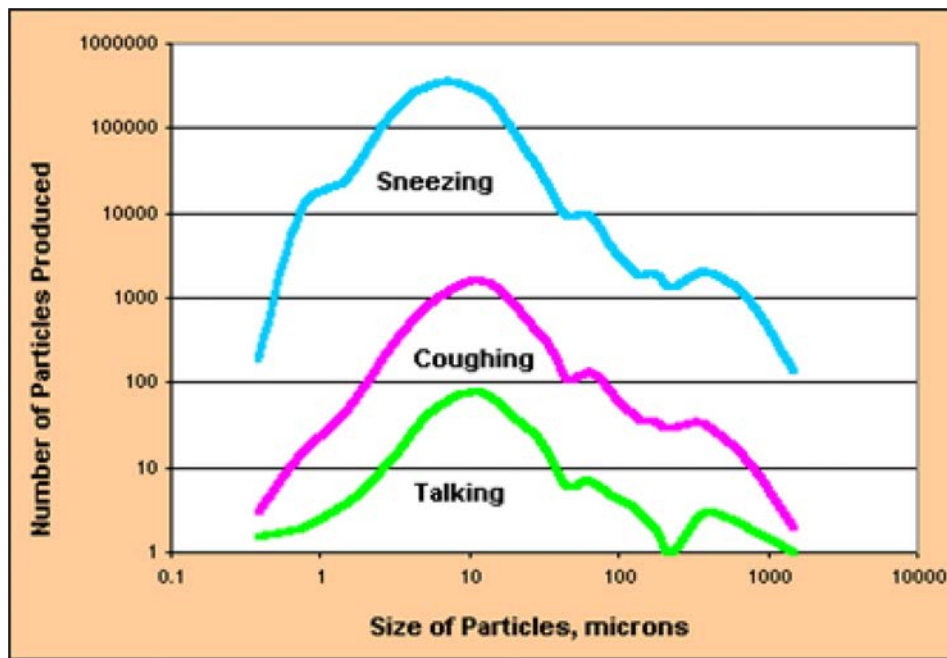

*Activities such as sneezing, coughing or talking add condensate nuclei particles to air and increases the possibility of transmission of disease.*

## System Approach Central Air Handling Units

Central Air Handling Units condition the largest percentage of outside air (OA) entering a building. These units contain all, or some, of the following components: particulate filters, heating and cooling coils, humidification systems, activated carbon systems, fans, dampers and motors. This exacerbates the need to remove a variety of contaminants to maintain the effective operation of the system and its components and to provide a healthy environment for its tenants. In some instances the air being returned to the CAHU is more contaminated than the OA requiring the need for particulate and sometimes odor removal at the source.

NAFA's best practice for a CAHU is a MERV 13 filter at prescribed airflow. MERV 13 filters are recommended because of their ability to capture most fine particulate matter (PM 2.5) that can be dangerous or have adverse health effects for building occupants.

In some cold weather climates, a summer and winter bank are used with the pre-filter alternating positions depending upon the season while the secondary filter remains in the downstream winter position.



*Photograph courtesy of Engineered Air*

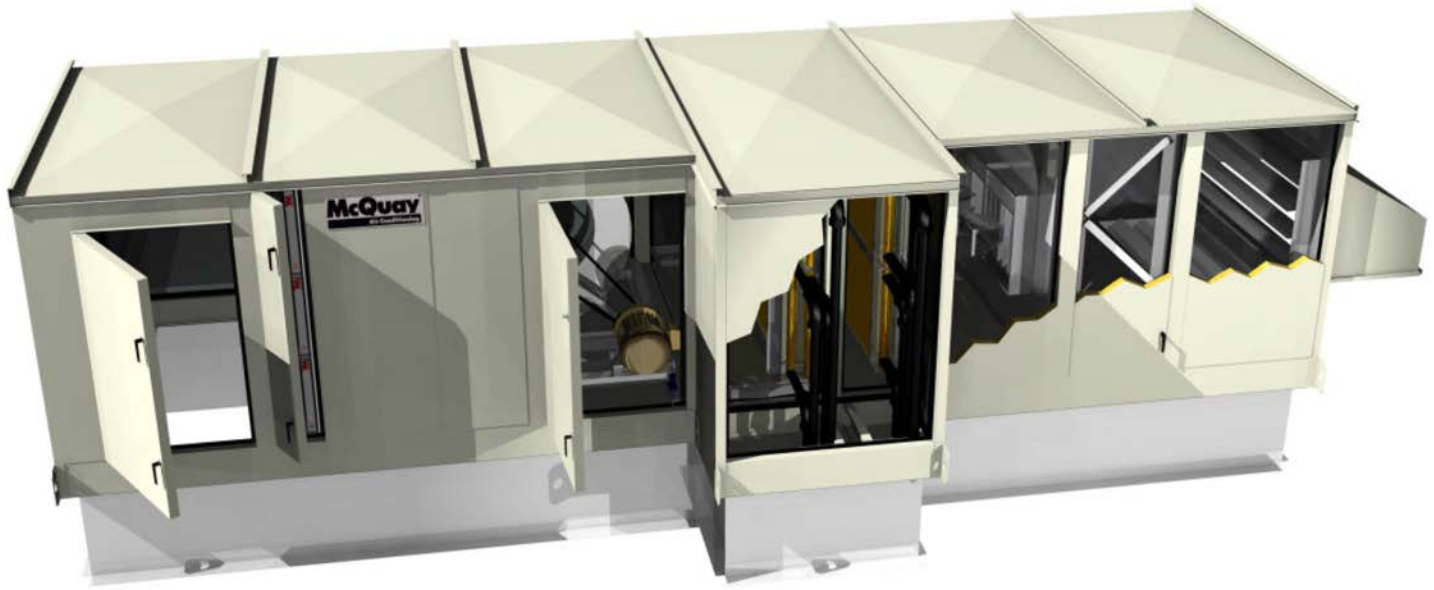

*Photograph courtesy of McQuay International*

## Rooftop Air Handling Units

A Rooftop Air Handling Unit (RAHU) maintains comfort conditions in a zone by providing a constant volume of air that varies according to load. Rooftop units can be the entire source of heating and cooling for a building or supplemental systems to the existing Heating, Ventilating and Air Conditioning (HVAC) system. A MERV 13 filter is recommended.

## Make-up Air Units

Make-up air (MUA) units are designed to provide ventilation air into a space or replace air exhausted from the building. It may be used to prevent negative pressure within the building or to control the contaminant level in the space. An example of MUA units for commercial use is the parking garage where the units provide replacement outside air when contaminated vehicle air is exhausted. An MUA unit operates on 100% outside air and a MERV 13 filter is recommended for units supplying conditioned spaces. For an MUA serving non-conditioned spaces, a MERV 8 filter is recommended.



*Photograph courtesy of Engineered Air*



**Figure 4.1 Ductless Split System and Room Air Conditioners; Mini-Split System**

*These units are not intended for air filtration but are used for environmental control. Follow manufacturer's recommended guidelines for filtration.*

## Unitary Units

Unitary units are factory made systems that normally include heat/cool coils, fan, motor, humidification, filtration, and ventilation components. Unitary systems are commonly used as compartmental floor units to provide conditioned air. The best practice recommendation is a MERV 13 filter. The task for this filter is to remove the contaminants which are primarily generated within the indoor space.



**Figure 4.2.**

*Exterior air conditioning unit – David Lee*

*These units are not intended for air filtration but are used for environmental control. Follow manufacturer's recommended guidelines for filtration.*



**Figure 4.3. Photographs courtesy of Engineered Air**

## Unit Ventilators

Unit ventilators are an assembly of elements whose principal function is to condition a space. They are often used in Higher Education facilities to provide an air current for windows to prevent condensation. Components of unit ventilators include a fan, motor, coil or heating element, filter and an enclosure. No central air is provided to a unit ventilator so air is taken from the space and conditioned at the unit. A unit ventilator can also be supplied with an outdoor air damper for ventilation. A MERV 8 filter is recommended for this application.

## Fan Coil Units

Fan coil units are small unitary systems that provide a combination of heating or cooling to condition a space. The units can sometimes be supplied with outdoor dampers for ventilation. Fan coils are often used to supply conditioned air to areas such as elevator machine rooms, electrical vaults, telecommunication rooms etc. Recommended filtration is MERV 8.

## Self Contained Units

Self contained units are typically constant volume heat/cool units. Outside air to meet ventilation requirements is usually provided by a dedicated outside air duct. Higher Education facilities are often served by multiple self contained units. Recommended filtration is MERV 8.

## Heat Pumps

Commercial heat pumps are unitary systems that can operate either in heating or cooling mode. Conditioned air is discharged either directly into the zone or into a ducted system. Recommended filtration is MERV 8. Induction Units  
Induction Units are used to save space and give temperature control for each room in which they are installed. Induction units are made for handling the different cooling and heating loads in the perimeter areas of larger buildings. They can be used in combination with a central HVAC system or as a stand-alone system recirculating air within the space. Some induction units have the ability to bring in outside air. They are commonly used in hospitals, hotels, apartments, office buildings, schools, and universities. Recommended filtration is MERV 8.



Figure 5.1. Photograph courtesy of McQuay International



Figure 5.2.



Figure 5.3. Picture courtesy of Carrier Corp.



## Induction Units

Induction Units are used to save space and give temperature control for each room in which they are installed. Induction units are made for handling the different cooling and heating loads in the perimeter areas of larger buildings. They can be used in combination with a central HVAC system or as a stand-alone system recirculating air within the space. Some induction units have the ability to bring in outside air. They are commonly used in hospitals, hotels, apartments, office buildings, schools, and universities. Recommended filtration is MERV 8.



Figure 6.1

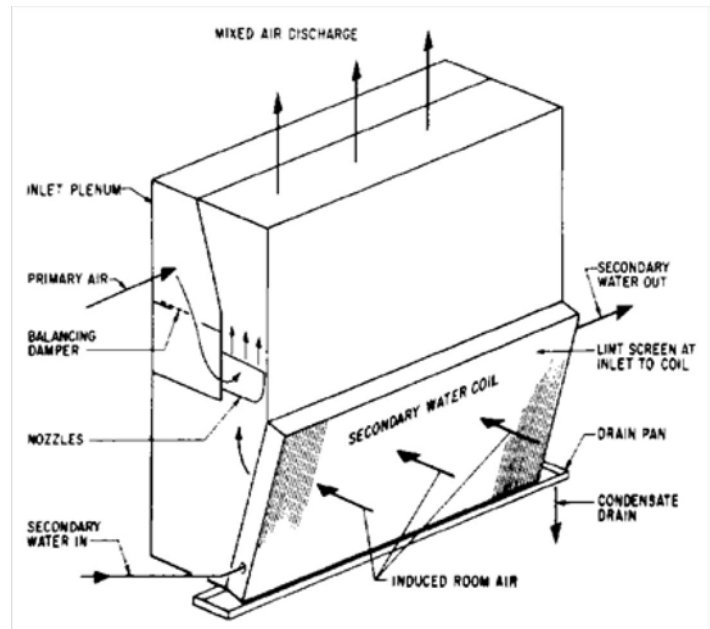

Figure 6.2

## Application Approach

### Localized Supply and Exhaust

The complexity of operating a Higher Education complex necessitates the use of special ventilation, cooling and filtration strategies for operational activities such as: telecommunication rooms, data rooms, and mechanical equipment. In these applications equipment protection and their ultimate performance are paramount. A MERV 13 filter is recommended for these applications.

### Internal Construction

Renovation and internal construction present a major operational balancing act for the facility management group. They are responsible to maintain operation of the building while activities such as painting, carpet replacement, and complete floor overhauls are taking place. For small renovations on an individual floor then consideration must be made for the other tenants on the floor. In these situations, if possible, the work should be performed during off hours and the contaminants removed at the source. During any construction that can affect building operations, a negative air HEPA fan unit in conjunction with barrier isolation should be used. This will remove the particulate from the area under renovation before it is exhausted outside or enters the occupied space. Any odors created during this process will have to be addressed with the addition of molecular contaminant removal filters.

For larger projects, such as complete floor overhauls, consideration for contaminants returning to the central air handling system will need to be addressed. Additional filters of a minimum MERV 8 or higher should be temporarily installed at each return air grill on the individual floor under construction and should be removed immediately prior to tenant occupancy. During construction filters need to be monitored and possibly changed more frequently due to the higher particulate load. Any odors created during this process may need to be addressed with the addition of molecular contaminant removal filters.

For more information see SMACNA – IAQ “Guideline for Occupied Buildings Under Construction.”

## Food Preparation

Many Higher Education buildings contain restaurants, cafeterias, and specialty food and beverage providers. Minimizing the food odors within a building requires that these areas to be kept under a negative pressure with respect to adjacent spaces. In many cases the air is contaminated with grease, particulate, and odor and these may need to be removed with filtration before exhausting. We will not be addressing this specific application in this guideline.

## Business Processing Center

Rooms designated and dedicated for activities such as printing, photocopying, document shredding, or other specialized office activity may lead to the generation of odor and particulate contamination. This issue requires special consideration to limit the spread of the contamination to the rest of the building. Air from these activities should be filtered for particulate and odor removal at the source or exhausted directly outdoors. A particulate filter of MERV 13 is recommended along with molecular contaminant removal filters for odor and gaseous removal. Molecular filtration may be necessary but will not be discussed in this guideline.

## Health Safety

Certain buildings and geographic locations may be more at risk for bioterrorism attacks than standard Higher Education facilities. For information on filtration for these types of buildings, please refer to the NAFA Position Statement on Bioterrorism. Also, see “Risk Management Guidance for Health, Safety, and Environmental Security under Extraordinary Incidents.”

*“9/11 raised the issue of the quality of the indoor air environment from a comfort and housekeeping issue to a health and safety issue”*

- William Coad  
ASHRAE President 2001-2002

## Operation and Maintenance

The following is a list of some of the more important factors to consider when operating and maintaining an HVAC system. As a supplement to manufacturers’ guidelines, see NAFA’s Installation, Operation and Maintenance of Air Filtration Systems manual.

### Installation of Filters and System Integrity

An understanding of the entire HVAC system is helpful to ensure that the air filters are properly installed. When changing model or design, consult manufacturer’s instructions. Maintaining the system’s integrity is vital to proper air filtration. After installation, the system, including filter frames, fastening devices and gaskets should be checked to insure that there are no leaks or gaps. A properly sealed system will prevent bypass and maintain system pressure.

Additional information regarding maintenance of HVAC and filter systems may be found in the ANSI/ASHRAE/ACCA Standard 180, “Standard Practice for Inspection and Maintenance of Commercial Building HVAC Systems.”

## Maintenance

A preventive maintenance program should be in place and include inspection of filter frames, fastening devices, gaskets and ductwork. Removing and replacing damaged or defective gasketing and duct insulation will keep air from bypassing the filter. Keeping the coils and blower free from dirt and debris by regular cleaning will improve airflow, increase system efficiency and maintain overall integrity. In summary, good housekeeping will keep the HVAC system in proper working order and will provide the facility with air that is not only heated and cooled, but also cleaned with a reduction in contaminant levels.



Figure 8.1

## Monitoring of Airflow and Pressure Drop

All filters in an HVAC system increase the resistance to the flow of air. This increase is called “pressure drop.” As an example, in a draw-through system as the filters load and the resistance increases, the fan pressure is lower on the downstream side, hence the pressure “drop” downstream, of the filters. This drop can be measured with a pressure sensing device such as a manometer or magnehelic gage. All HVAC units should have a pressure-sensing device installed to accurately monitor the airflow and pressure drop across the filter bank. When a filter has exceeded its useful life, based on life cycle costing (LCC), it should be replaced. Leaving a filter in place after this point may increase operational and energy costs and could damage the HVAC system.

## Disposal

Both particulate and molecular filters should be disposed of in accordance with all local, state and federal regulations. Spent carbon in molecular filters may sometimes be returned to the manufacturer for reactivation.

## Summary

This guideline identifies what NAFA considers as the “best practice” recommendation for filtration in Higher Education Buildings. It looks at both a system and application specific approach to improve indoor air quality and equipment protection in Higher Education Buildings. It raises awareness of the filter as one element in the filtration system by emphasizing the importance of the filter hardware system, proper installation and maintenance.

# Glossary

**Air Filter/Air Cleaning:** a device used for the removal of particulate or gaseous impurities from the air.

**AHU:** air handling unit describes the unit or units supplying a building with conditioned air. It can be described as the lungs of a building.

**ANSI:** American National Standards Institute – As the voice of the U.S. standards and conformity assessment system, ANSI empowers its members and constituents to strengthen the U.S. marketplace position in the global economy while helping to assure the safety and health of consumers and the protection of the environment.

**ASHRAE:** American Society of Heating, Refrigerating and Air Conditioning Engineers. ASHRAE is an international organization that sets standards and guidelines for the heating, ventilating, air conditioning, and refrigeration industry.

**ACH:** Air changes per hour computed by taking the cubic area of a space and dividing by the cubic feet per hour of air supplied to it.

**CAFS:** Certified Air Filter Specialist accreditation granted by NAFA to those who pass an exam on air filtration.

**DOP:** Dioctyl Phthalate is a chemical used to challenge HEPA filters. Factory testing involves heating DOP to produce a monodispersed particle challenge and distribution through a Laskin nozzle produces a polydispersed particle challenge.

**FPM:** Feet per minute describes velocity of air. FPM is always positive and always measured in one direction.

**HEPA:** High Efficiency Particulate Air filter – describes a filter that achieves a minimum of 99.97% efficiency on 0.3 micrometer particles or similar challenge.

**HVAC&R:** Heating, Ventilating, Air Conditioning and Refrigeration.

**IAQ:** indoor air quality describes the quality of air supplied to an interior space. The goal of IAQ is to provide air that is clean and healthy to building occupants.

**In-situ:** translated means “in position.” This refers to measuring a filter installed in a system commonly using cold DOP for HEPA filters to test for leaks or using ambient air and a particle counter to perform ANSI/ASHRAE GP 26.

**Life Cycle Costing (LCC):** the investigation and valuation of the environmental impacts of air filters.

**Makeup Air:** air supplied to a space for the purpose of replacing exhausted air from a space.

**MERV:** Minimum Efficiency Reporting Value refers to the lowest efficiency of a filter when tested in accordance with ANSI/ASHRAE Standard 52.2 2012.

**NAFA®:** registered acronym for the National Air Filtration Association, the trade association for air filter manufacturers and distributors, worldwide.

**OSHA:** Occupational Safety and Health Administration, the group that is charged with enforcement of health and safety legislation.

**PM 2.5:** Fine particulate matter (PM2.5) is an air pollutant that is a concern for people’s health when levels in air are high. PM2.5 are tiny particles in the air that reduce visibility and cause the air to appear hazy when levels are elevated.

**PPM:** parts per million refers to the concentration of a substance within another substance. One ppm is equivalent to 1 milligram of something per liter of air (mg/l).

**Pressure Drop:** describes the drop in static pressure of the air from the upstream side of a filter to the downstream side.

**OA:** outdoor air.

## Bibliography

ANSI/ASHRAE Standard 62.1 – 2010. Ventilation for Acceptable Indoor Air Quality.

ANSI/ASHRAE/ACCA Standard 180 – 2008. Standard practice for Inspection and Maintenance of Commercial Building HVAC Systems

2011 ASHRAE Handbook – HVAC Applications.

2008 ASHRAE Handbook – HVAC Systems and Equipment.

2009 ASHRAE Handbook – Fundamentals.

Particle Management for HVAC Systems. Thomas C. Ottney. ASHRAE Journal July 1993.

ASHRAE Report of Presidential Ad Hoc Committee for Building Health and Safety under Extraordinary Incidents on Risk Management Guidance for Health, Safety, and Environmental Security under Extraordinary Incidents, 26 January 2003.

Z204-94 Guideline for Managing Indoor Air Quality in office buildings. CSA.

IAQ and HVAC Workbook. 3rd Edition – D. Jeff Bruton. Guidance notes for the Management of IAQ in Offices and Public Places – IAQ Management Group, Government of Hong Kong.

Taking Charge Against the New Threat. H.E. Barney Burroughs. RSES Journal January 2002.

NAFA Guide to Air Filtration, National Air Filtration Association

Installation, Operation, and Maintenance of Air Filtration Systems, National Air Filtration Association

Sheet Metal Air Conditioning Contractors National Association (SMACNA) publication, “IAQ Guidelines for Occupied Buildings Under Construction” 601 N. Fairfax St. Suite 250, Alexandria, VA 22314

## Photographs

Nestrovich, Peter. “Photo permission Part1” to Kevin Delahunt, 22 March 2011

Nestrovich, Peter. “Engineered Air Equipment Pictures” to Kevin Delahunt, 22 March 2011

David Lee, 2011 used under license from Shutterstock.com

This NAFA Guideline has been provided, courtesy of:

**Independent Filter Service**

82 Northern Road,  
Heidelberg West, 3081, Victoria  
T: (03) 9458 3644  
E: [sales@independentfilter.com.au](mailto:sales@independentfilter.com.au)  
[www.independentfilter.com.au](http://www.independentfilter.com.au)



The source for expertise, education and standards in air filtration.

Copyright 2014, 2016  
National Air Filtration Association  
22 N. Carroll St, Ste 300, Madison, WI 53703  
(608) 310-7542  
[nafahq.org](http://nafahq.org)